

Industrial Rol•a•Door®

Gliderol® Continuous Sheet
Curtain Roller Door



Unprecedented in Construction and Design in terms of technical excellence and superior design, the Gliderol® Industrial Rol•a•Door® is unsurpassed in the manufacturing industry. The Gliderol® Roller Door will undoubtedly add style and character to any building; the Industrial Rol•a•Door® can be made to suit most commercial/industrial openings, and is designed to provide reliable service for years to come.

Leading the way in technology world wide Gliderol® Garage & Industrial Doors is a wholly owned Australian manufacturing company, with over fifteen international licensees world wide. The Gliderol® Industrial Rol•a•Door®, through years of research and development has evolved into a product demanding world wide attention. Computer assisted technology has enabled Gliderol® to develop its manufacturing processes to produce an award winning industrial door that is cost effective, strong, hard-wearing and safe.

Quality and Safety that can be relied on The Gliderol® Industrial Rol•a•Door® will provide you with strength and safety as a priority at all times. The strength gained from the unique broadline profile and aluminum bottom rail is unrivalled.

A Gliderol® Roller Door will always remain a very safe roller door for you to operate throughout its life span. The unique spring assisted spindle assembly will enable the Roller Door to always open and close easily, providing reliable performance at all times.

Manufactured by
**Gliderol® Garage &
Industrial Doors Ltd**

Davy Drive
North West Industrial Estate
Peterlee
Co. Durham SR8 2JF

Telephone: 0191 518 0455
Facsimile: 0191 518 0548

Gliderol® Industrial Rol•a•Door®

Gliderol® Continuous Sheet Curtain Roller Door

Features

(1) Roller Door Curtain Gliderol® rollformed **CORUS STEEL®** sheet panels. Weather resistant and durable, able to withstand the harshest of conditions. The curtain provides industrial strength and quality in design to enhance overall appearance of the Roller Door.

(2) Spring Assistance The Gliderol® Roller Door with its spring assisted mechanism offers precise balance enabling the user efficient easy operation. A fine balance between the weight of the curtain and the upward pull of the springs is maintained regardless of the position of your door.

(3) Drum Wheel Gliderol® was the first to employ the use of engineering plastics in the manufacture of the drum wheel. This nylon drum wheel has been developed over time into a hard-wearing high performance component.

(4) Polyglide™ Revolutionary new material developed by Gliderol® Doors specifically for Roller Door operation. Allows effortless operation, with minimum noise and friction. Polyglide was tested for 22,000 cycles continuous use, the equivalent of more than 21 years service, based on three cycles per day.

(5) Weatherseal Durable weatherseal prevents any undesirable material entering your garage from the outside when the Gliderol® Roller Door is closed.

(6) Bottom Rail Aluminum in construction, this bottom rail has been specifically designed to reinforce your Roller Door against intruder penetration. Lockseamed to the Roller Door curtain, the bottom rail will provide sustained security and strength.

(7) Door Stop/Roller Designed specially to reduce friction and to assist in ease of operation when opening and closing your Gliderol® Roller Door.

(8) Direct Chain Wheel Constructed of glass-reinforced nylon, the direct chain wheel provides the user with smooth, efficient lifting assistance.

(9) Chain Guide Prevents the chain from slipping or releasing from chain wheel, ensures that safety is maintained at all times.

(* External Shoot Bolt) Practical locking mechanism enabling you to secure the Roller Door with padlocks from outside. Can be mounted at any height to suit individual preferences.

(* Optional Windlocking) Secure your Gliderol® Roller Door against prevailing winds. Windlock Clips fixed to the Roller Door curtain secure the door guide (*Cyclone rated. Certified AS1170-2).

(* Optional Planetary Gearing) assisted lifting mechanism purposefully designed to enable safe, easy lifting operation of very large doors. Standard on any manual Industrial Rol•a•Door covering an opening of greater than 10.5 square metres.

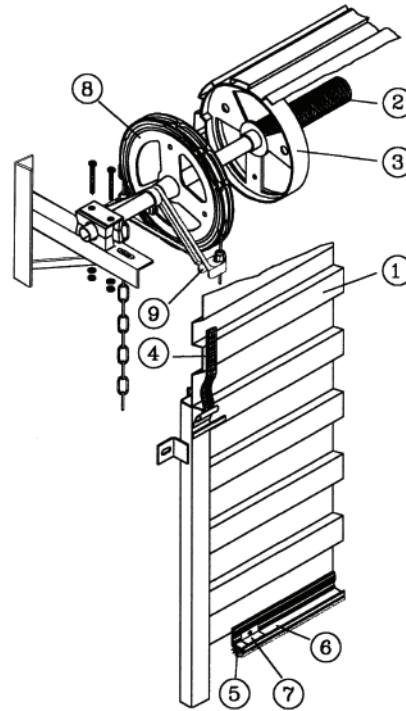

Industrial Rol•a•Door® perfect for multiple storage facilities.



Gliderol Guarantee All new Gliderol Roller Doors come with the Gliderol guarantee. Complete warranty details will be clearly outlined at point of sale.

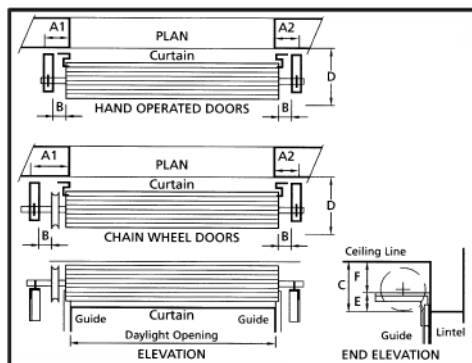

DIMENSION PANEL (Minimum sizes) mm						
SERIES B INDUSTRIAL	Side Room A1	Side Room A2	B	Head Room C	D	E F
Hand Operated Up to 2400 high	150	125	50-100	460	540	190 270
Up to 500 high	150	125	50-100	490	560	205 285
Chain Operated Up to 2400 high	225	125	50-100	460	540	190 270
Up to 3000 high	225	125	50-100	490	560	205 285
Over 3000 high	225	125	50-100	530	580	230 300
STANDARD CURTAIN WIDTHS						
1000, 1300, 1600, 1900, 2200, 2800, 3100, 3430, 3700, 3760, 4300, 4370, 5000, 5100						
CURTAIN WIDTH						
DAYLIGHT OPENING PLUS 100mm						